



Magnetic Inductive Flow Meter

All-metal design

IO-Link

- For measuring and monitoring of conductive liquids
- Accuracy: $< \pm (0.8\% \text{ of reading} + 0.5\% \text{ of full scale})$
- Flow and temperature measurement
- Monitoring, transmitter function, dosing
- Bidirectional measuring
- $p_{\max}: 16 \text{ bar}; t_{\max}: 140 \text{ }^\circ\text{C}$
- All-metal design: stainless steel
- Connection $1/4", 1/2", 3/4", 1", 2"$

90° rotation programmable

90° rotation programmable

Description

The new flow meter MIM was developed for measuring and monitoring smaller- and medium-sized flow of conductive liquids in pipes.

The device operates according to the electromagnetic measurement principle. According to Faraday's Law of magnetic induction, a voltage is induced in a conductor moving through a magnetic field. The electrically conductive measuring agent acts as the moved conductor. The voltage induced in the measuring agent is proportional to the flow velocity and is therefore a value for the volumetric flow. The flowing media must have a minimum conductivity. The induced voltage is picked up by two sensing electrodes which are in contact with the measuring agent and sent to the measuring amplifier.

The flow rate will be calculated based on the cross sectional area of the pipe.

The measurement is not depending on the process liquid and its material properties such as density, viscosity and temperature. Two given outputs can be set to be switch, analogue or frequency. Also a dosing function can be selected, where output 1 is set as switch NPN/PNP/PP and output 2 is set as control input.

Significant Characteristics

- Stainless steel design
- Flow- and temperature measurement
- Monitoring, dosing and transmitter function
- Dosing function with external control input
- Coloured, multi-parameter configurable TFT-display, rotatable in 90° steps
- Bidirectional measuring
- Intuitive setup menu via 4 optical touch keys
- 2 configurable outputs (pulse-/frequency-/alarm- and analogue output)
- Grand and resettable totaliser
- Drinking water approval

Technical Details

Measurement process:	electromagnetic
Range:	see order details
Media:	conductive fluids
Minimum conductivity:	≥20 µS/cm (≥35 µS/cm for measuring range 01H/01G)
Max. pressure:	16 bar
Accuracy:	<±(0.8% of reading+0.5% of full scale)*
Repeatability:	±0.2% of full scale
Response time flow t ₉₀ (alarm/pulse/ frequency output):	<100 ms
(analogue output):	<1 s

Temperature measurement

Sensor:	PT1000
Accuracy:	≤±2°C (flow >0.2 m/s)
Measuring range:	temperature range of medium
Response time temperature t ₉₀ (signal output):	<20 s
Mounting position:	in all directions
In-/outlet:	3xDN/2xDN
Pressure drop:	see pressure loss diagram
Operation:	4 optical touch sensors, useable with hand gloves**
Housing:	stainless steel 1.4404, display screen PMMA

Wetted parts

The wetted parts of MIM-13*** are in conformance with DVGW 270 and WRAS guidelines for drinking water approval.

*** except measuring range code "35"

Connection fitting:	stainless steel 1.4404
Insulation parts:	PEEK
Electrodes:	stainless steel 1.4404
Seals:	FKM (Option: EPDM)
Protection:	IP67
Conformity:	Regulation (EC) No 1935/2004 on materials and articles intended to come into contact with food

* Under reference conditions: media temperature: 15°C...30°C, 1 cSt, 500 µS/cm, 1 bar

ambience temperature: 15°C...30°C

** Limited functionality with black rubber gloves

Technical Details (continued)

Temperature ranges

Design	Electronics	Model	Seals material	Media temperature	Ambient temperature
compact version	C3T	MIM-12 MIM-13	FKM	-20°C ... +70°C ²⁾	-20°C ... +60°C
			EPDM		
remote version (PVC cable)	P02 ¹⁾	MIM-12 MIM-13	FKM	-20°C ... +85°C	-20°C ... +60°C (display electronics)
			EPDM		-20°C ... +85°C (sensor)
remote version (ETFE cable)	E02 ¹⁾	MIM-12	FKM	-20°C ... +140°C	-20°C ... +60°C (display electronics)
			EPDM		-20°C ... +140°C (sensor)
		MIM-13	FKM	-40°C ... +140°C	-20°C ... +60°C (display electronics)
			EPDM		-40°C ... +140°C (sensor)

¹⁾ Cable length: 02 = 2 m, 05 = 5 m, 10 = 10 m, 15 = 15 m, 20 = 20 m

²⁾ Continuous -20°C ... +70°C, short-term up to max. +85°C (for max. 60 minutes at max. +40°C ambient temperature and repetition earliest after 4 hours). Use of the electrical outputs remains limited to temperature range -20°C ... +70°C.

Electrical data

Supply voltage:	19-30 V _{DC} , internal power consumption max. 200 mA	Electrical connection: plug M12x1, 4-pin
Display:	TFT display, 128x128 pixels, 1.4" display orientation in 90° steps adjustable	Shock resistance DIN EN 60068-2-27:2010: 20 g (11 ms)
Display repetition rate:	0.5 ... 10 s, adjustable	Vibration resistance DIN EN 60068-2-6:2008: 5 g (10 ... 2000 Hz)
Pulse output	Push-Pull, freely scalable, configurable for partial and accumulated totaliser	Environmental testing DIN EN 60068-2-30:2006: severity level b
Frequency output	Push-Pull, freely scalable, 2 kHz @ overflow f _{min} @ FS = 50 Hz f _{max} @ FS = 1000 Hz	
Alarm output:	NPN, PNP, Push-Pull, configurable max. 30 V _{DC} , max. 200 mA short-circuit proof	
Analogue output:	active, 3 wire, 0(4)-20 mA, max. load 500 Ω or 0(2)-10 V _{DC} , (R _i = 500 Ω) (factory calibrated with R _L = 1 MΩ)	
Control input:	active signal U _{high} max. 30 V _{DC} 0 < Low < 10 V _{DC} 15 V _{DC} < High < Vs	
Dosing function:	Dosing output OUT2: Push-Pull, High active Control input OUT1: START/STOP 0.5 s < t _{high} < 4 s RESET t _{high} > 5 s	

Connection/ranges

Connection	Inside diameter (DN)	Range
G ¼	2.4x3 mm	0.01 ... 1 l/min
G ½	5 mm	0.03 ... 3 l/min / 0.04 ... 10 l/min
½" NPT	5 mm	0.48 ... 48 GPH / 0.01 ... 2.6 GPM
G ¾	10 mm	0.1 ... 25 l/min / 0.2 ... 50 l/min
¾" NPT	10 mm	0.025 ... 6.6 GPM / 0.05 ... 13 GPM
G 1	15 mm	0.2 ... 50 l/min / 0.4 ... 100 l/min
1" NPT	15 mm	0.05 ... 13 GPM / 0.1 ... 26 GPM
G 2	see dimensional drawing	1,5 ... 350 l/min / 3 ... 650 l/min
2" NPT	see dimensional drawing	0,4 ... 90 GPM / 0,8 ... 170 GPM

Configuration of outputs

Output 1 (OUT1, PIN 4)	Output 2 (OUT2, PIN 2)
Analogue output 4-20 mA	Analogue output 4-20 mA
Analogue output 0-20 mA	Analogue output 0-20 mA
Analogue output 2-10 V	Analogue output 2-10 V
Analogue output 0-10 V	Analogue output 0-10 V
Switching output NPN/PNP/PP	Switching output NPN/PNP/PP
Pulse output PP	Pulse output PP
Frequency output PP	Frequency output PP
Communication mode KofCom	
Communication mode IO-Link	
Control input	
Control input dosing function	Dosing output

IO-Link specification

Manufacturer ID:	1105 (decimal), 0 x 0451 (hex)
Manufacturer name:	Kobold Messring GmbH
IO-Link specification:	V1.1
Bitrate:	COM3
Minimal cycle time:	1,1 ms
SIO-Mode:	yes (OUT1 in configuration IO-Link)
Block parameterisation:	yes
Operational readiness:	10 s
Max. cable length:	20 m

Electrical Connection MIM-...C3T

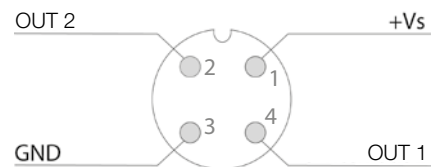

Order Details (Example: **MIM-12 15H G5 C3T 0**)

Model	Range	Connection	Electronics	Special version
MIM-12 = housing/ electrode VA, FKM seal MIM-13⁴⁾ = housing/ electrode VA, EPDM seal	01H¹⁾ = 0.01 ... 1 l/min 01G²⁾ = 0.16 ... 16 GPH	G2 = G ¼ male	C3T = compact, TFT display, 2 outputs (current/voltage/ pulse/frequency/alarm output configurable), M12x1 plug P02³⁾ = remote version, TFT display, 2 m PVC cable, max. 85 °C E02³⁾ = remote version, TFT display, 2 m ETFE cable, max. 140 °C	0 = without K⁵⁾ = including calibration report
	03H¹⁾ = 0.03 ... 3 l/min 05H¹⁾ = 0.04 ... 10 l/min	G4 = G ½ male		
	03G²⁾ = 0.48 ... 48 GPH 05G²⁾ = 0.01 ... 2.6 GPM	N4 = ½" NPT female		
	10H¹⁾ = 0.1 ... 25 l/min 15H¹⁾ = 0.2 ... 50 l/min	G5 = G ¾ male		
	10G²⁾ = 0.025 ... 6.6 GPM 15G²⁾ = 0.05 ... 13 GPM	N5 = ¾" NPT female		
	15H¹⁾ = 0.2 ... 50 l/min 20H¹⁾ = 0.4 ... 100 l/min	G6 = G 1 male		
	15G²⁾ = 0.05 ... 13 GPM 20G²⁾ = 0.1 ... 26 GPM	N6 = 1" NPT female		
	35H¹⁾ = 1.5 ... 350 l/min 40H¹⁾ = 3 ... 650 l/min	G9 = G 2 male		
	35G²⁾ = 0.4 ... 90 GPM 40G²⁾ = 0.8 ... 170 GPM	N9 = 2" NPT female		

¹⁾ l/min-package (nameplate (l/min or ml/min, °C, bar)), calibrated range and temperature °C



²⁾ GPM-package (nameplate (GPM or GPH, °F, PSI)), calibrated range and temperature °F

³⁾ Cable length 02 = 2 m, 05 = 5 m, 10 = 10 m, 15 = 15 m, 20 = 20 m. Wall mounting brackets (brackets incl. accessories) is included in the scope of delivery.

⁴⁾ Measuring range code 35 is not in conformance with DVGW 270 and WRAS guidelines

⁵⁾ Number of measuring points (standard): 5

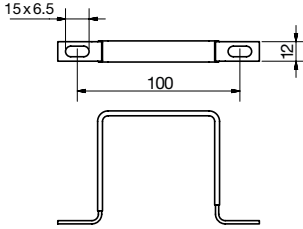
Accessories (Spare part)

Description	Model	Image	
Stainless steel wall mounting kit for remote version (2 brackets, without nuts/washers)	ERS-ZOK-023618		
Description	Model	Dimensions [mm]	Image
Clamping bracket set for wall mounting (stainless steel with partial polyolefin sleeve)	ZUB-MIM225128		

Order Details MIM Fitting Sets Accessory Kits*

Accessory kit number	Meter/ Process connection	Fitting set type	Dimensions [mm]	Image
ZUB-AD2U15P08	G 1/2 cap nut/ 1/4" NPT male	Cap nut and union		
ZUB-AD2G08P08	G 1/4 female/ 1/4" NPT male	Adapter		
ZUB-AD2G15P15	G 1/2 female/ 1/2" NPT male	Adapter		
ZUB-AD2G15N08	G 1/2 female/ 1/4" NPT female	Adapter		
ZUB-AD2G15N15	G 1/2 female/ 1/2" NPT female	Adapter		
ZUB-AD2U20P15	G 3/4 cap nut/ 1/2" NPT male	Cap nut and union		
ZUB-AD2G20P20	G 3/4 female/ 3/4" NPT male	Adapter		
ZUB-AD2G20N15	G 3/4 female/ 1/2" NPT female	Adapter		

* **Note:** All fitting kits include 2 x Klinger SIL® flat sealing gaskets

Order Details MIM Fitting Sets Accessory Kits* (continued)

Accessory kit number	Meter/ Process connection	Fitting set type	Dimensions [mm]	Image
ZUB-AD2G20N20	G 3/4 female/ 3/4" NPT female	Adapter		
ZUB-AD2U25P15	G 1 cap nut/ 1/2" NPT male	Cap nut and union		
ZUB-AD2U25P20	G 1 cap nut/ 3/4" NPT male	Cap nut and union		
ZUB-AD2G25N15	G 1 female/ 1/2" NPT female	Adapter		
ZUB-AD2G25N20	G 1 female/ 3/4" NPT female	Adapter		
ZUB-AD2G25N25	G 1 female/ 1" NPT female	Adapter		
ZUB-AD2G25T25	G 1 female/ 1" Tri-Clamp®	Adapter		
ZUB-AD2G50T50	G 2 female/ 2" Tri-Clamp®	Adapter		

* **Note:** All fitting kits include 2x Klinger SIL® flat sealing gaskets or 2x FKM O-rings (for ZUB-AD2G50T50)

Pressure Loss

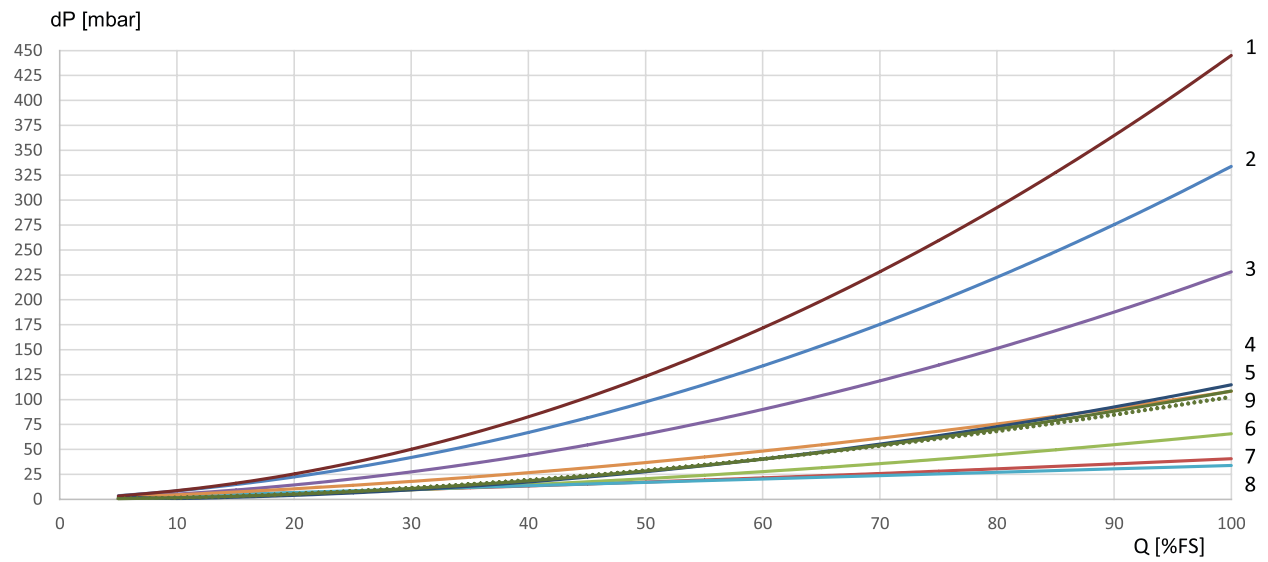

- ① MIM-1x40xx9
- ② MIM-1x05xx4
- ③ MIM-1x15xx5
- ④ MIM-1x35xx9
- ⑤ MIM-1x20xx6
- ⑥ MIM-1x10xx5
- ⑦ MIM-1x03xx4
- ⑧ MIM-1x15xx6
- ⑨ MIM-1x01xx2

Dimensions [mm]

Compact version

G
¼
½
¾
1

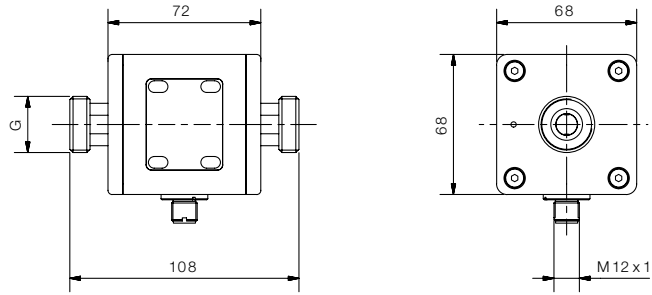

NPT
½
¾
1

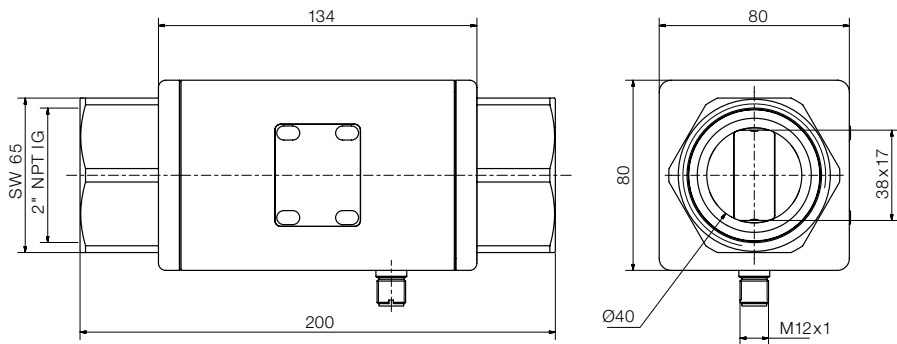
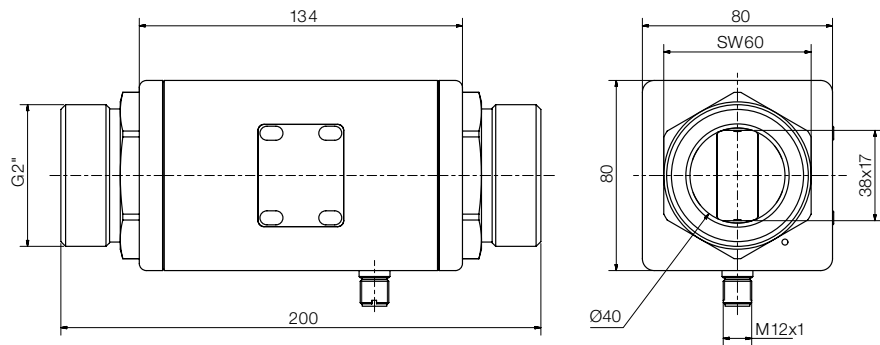
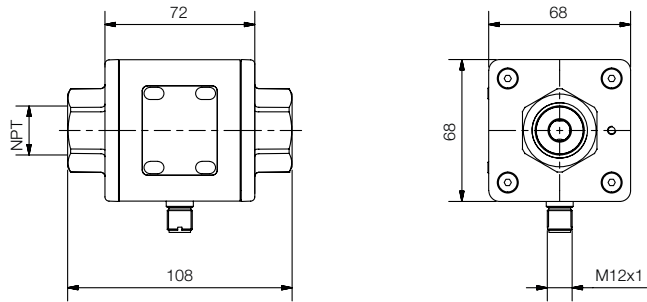

Dimensions [mm] (continued)

Remote version

Without wall mounting brackets

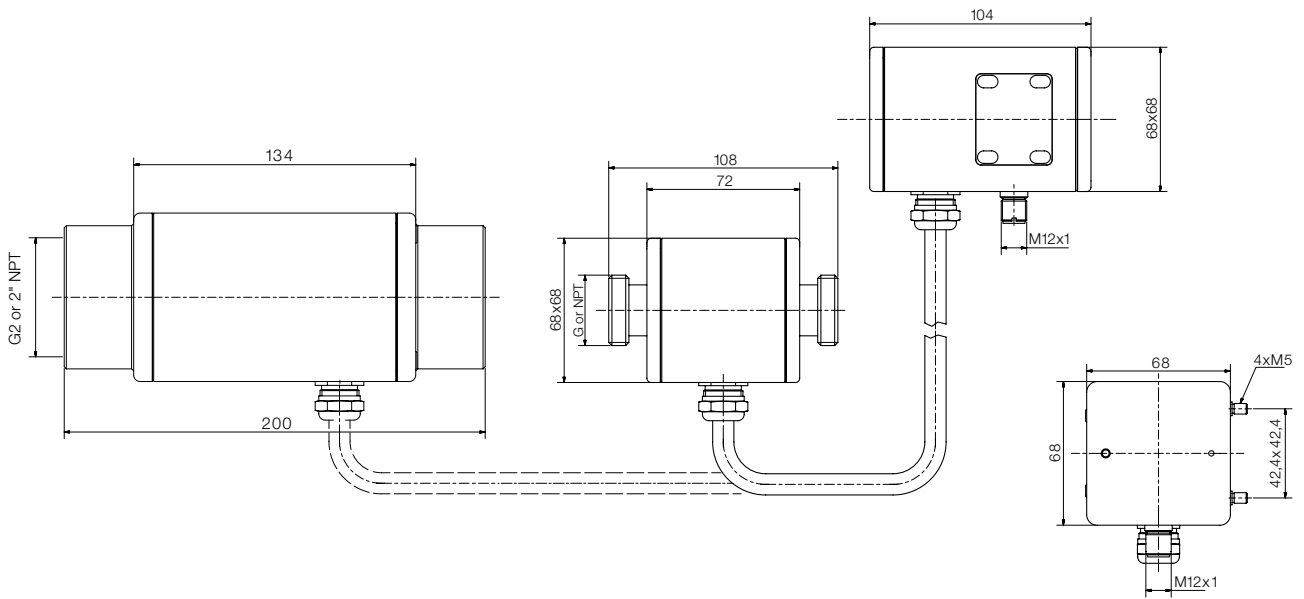

With wall mounting brackets

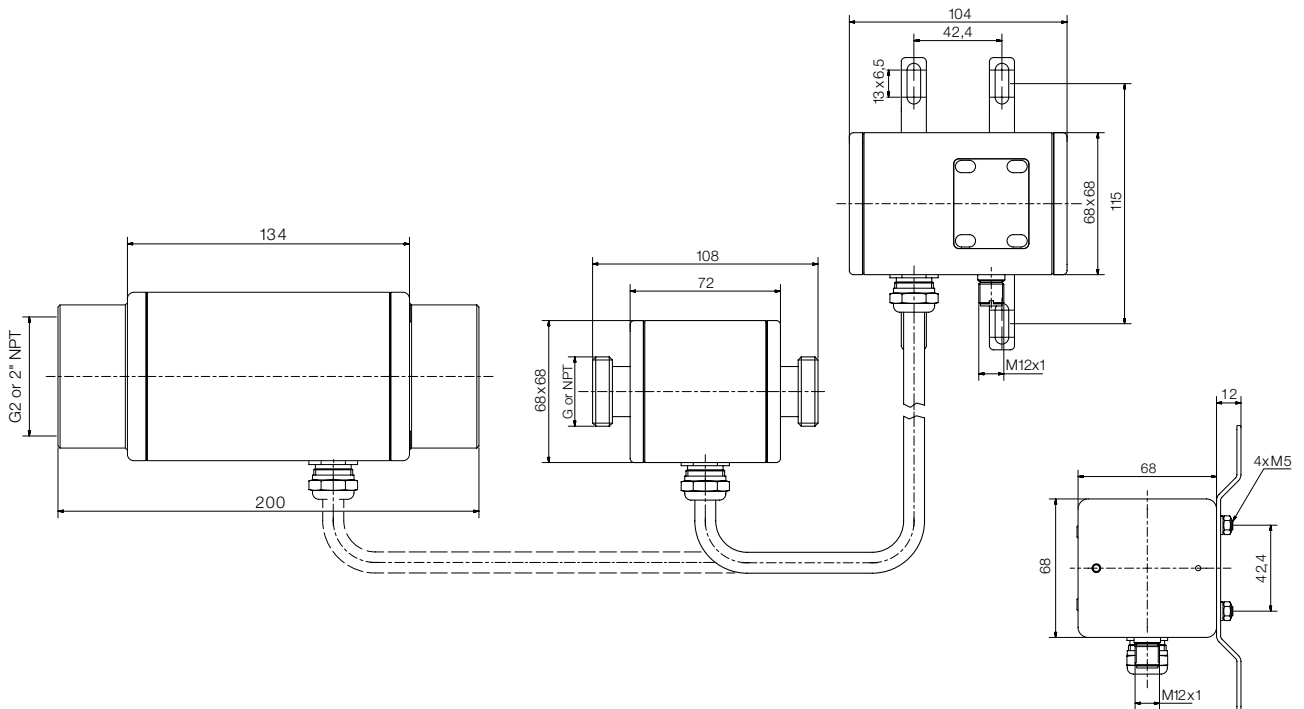

Measuring Mode, Display Layout »Single« configurable

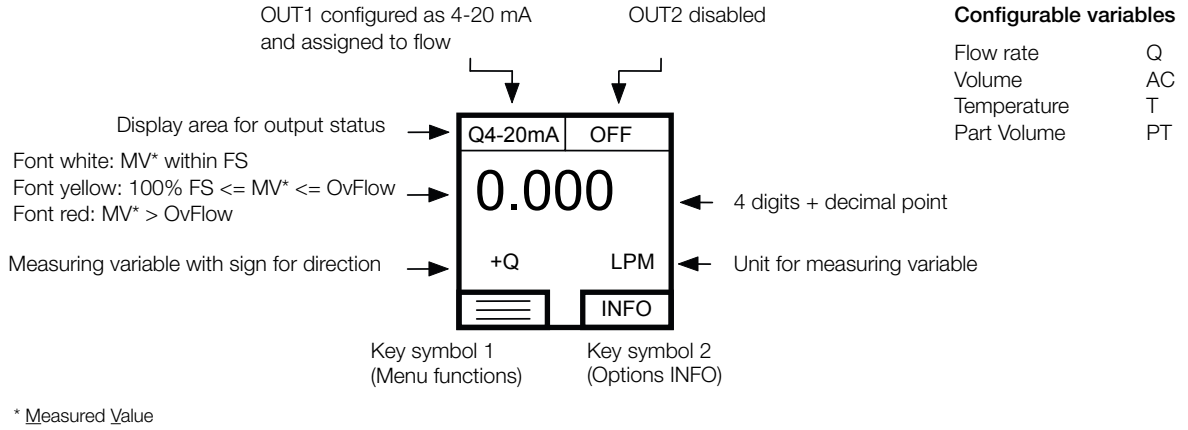

Measuring Mode, Display Layout »Dual« configurable

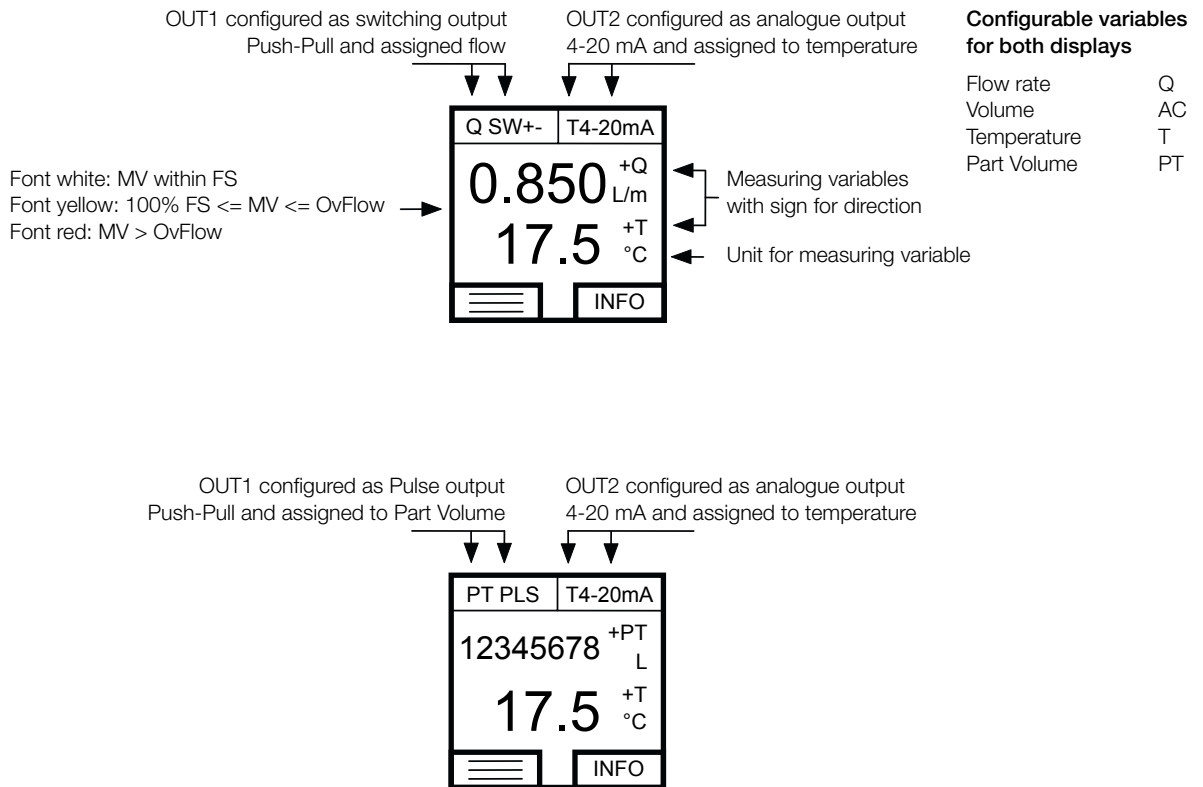



Compact version 1/4" - 1"

Rotatable in 90° steps



Compact version 2"

Remote display version



www.kompauto.com



sales@kompauto.com