

Neuron Ampere

The Ampere Sensor measures AC current and comes in several ranges from 10A to 500A RMS. The sensor comes with split core and is therefore easy to install onto existing power cables.



Integrated battery ensures up to 10 years of battery life. All measurements are easily accessible from web, app or API.

Features

- Integrated long life battery - up to 10 years lifetime
- Continuous measurement and instant alarm
- Adjustment of parameters such as measurement frequency on request
- Define your own alarm levels in the Neuron app
- Receive alerts as push notifications, emails or SMS
- Easily connect the sensor to the system with the QR-code on the sensor. Ensures immediate and accurate registration in the app on your phone/PC/tablet
- The sensor transmits data to your nearby Neuron Gateway which then again communicates with the Neuron Cloud

Typical Applications

- HVAC & pumps
- Refrigeration
- Industrial motors
- Fans
- Lighting
- Energy audits

Neuron System Benefits

Sensor - Gateway - Cloud - App



- **Robust sensors**
Suitable for rough environments
- **Wireless**
Wireless sensor with integrated battery
- **Long lifetime**
Typical 10 years battery life
- **Quick installation**
Wireless, installed and operational in minutes
- **Collect and deliver data**
Data delivery through API and app
- **Broad offering**

Essentials

Measuring Range	10A	20A	50A	100A	150A	250A	500A
Measuring Frequency	Every 10 sec						
Report Frequency	Every 2 min, or immediately after measurement if trigger for critical data transmission is reached						
Expected Operating Time*	Up to 10 years						

*Depends on measurement frequency, amount of critical data transmissions and ambient temperature

General Description

The Neuron Ampere is a split-core current transducer allowing for easy installation around existing wire without the need to disconnect the electrical system. This makes it an ideal choice for retrofitting or upgrading existing systems.

The sensor is typically used for in industrial and commercial applications, including building automation, HVAC systems, industrial automation, renewable energy systems and power monitoring systems.

Neuron Ampere provides accurate and reliable measurement of current and can be used for various tasks like monitoring energy consumption, detecting load changes and identifying potential problems in the electrical system. The sensor is available in a broad range of current ranges.

Principle of Operation

The current transducer has a magnetic core that surrounds the conductor carrying the current to be measured. When the current flows through the conductor, it generates a magnetic field around it. This magnetic field induces a current in a coil that is wrapped around the core. The induced current is proportional to the current flowing through the conductor, and it can be used to determine the current value.

The output signal of the transducer is the induced current, which is used to drive the input of the Neuron wireless transmitter. The custom Neuron hardware digitizes this 0-10V output signal and transmits it through a nearby Neuron Gateway to the Neuron Cloud.

Every 10 second the sensor measures the current and if the current has changed more than 20% of the full-scale range since the last transmission, the sensor reports immediately. Otherwise, it reports every 2 minutes.

The symbol  on the product label refers to this data sheet for important information regarding intended use, requirements for the operating environment etc. If the equipment is used in a manner not specified by El-Watch, the protection provided by the equipment may be impaired.

Technical Specification

Operational Specification

Measuring Range***	10A	20A	50A	100A	150A	250A	500A
Resolution	0,01 A	0,02 A	0,05 A	0,1 A	0,15 A	0,25 A	0,5 A
Accuracy	2% of Full Scale						
Measuring Frequency*	Every 10 sec						
Report Frequency*	Reports every 2 min. Or immediately if trigger for critical data transmission is reached, see below						
Trigger for Critical Data Transmission*	20% of range change in measurement						
Operating Environment	Ambient temperature: -20 - 50 °C Relative humidity: 0-85% (non condensing) Altitude < 2000m above sea level Pollution degree: 2						
IP Grade	IP 40, indoor use						
Cleaning	Wipe clean with a damp cloth						
Radio Frequency	863-870 MHz / 902-928 MHz						
Battery Type	Li-SOCI2, 3.6V						
Expected Operating Time**	Up to 10 years						

* Adjustable on request

** Depends on measurement frequency, amount of critical data transmissions and ambient temperature

*** Current outside the measuring range may permanently damage the device



Physical Specification

Materials	POLYblend 65 FS / TPU						
Dimensions	10A	20A	50A	100A	150A	250A	500A
Width (mm)	34	34	34	34	34	49	61
Depth (mm)	49	49	49	49	58	52	58
Length (mm)	58	58	58	58	64	77	94
Diameter (mm)	16	16	16	16	17	24	36

Ordering Information

	Europe/The Middle East/Africa Part number	North America/Australia/New Zealand Part number
0 - 10A	422291	422429
0 - 20A	422292	422430
0 - 50A	422293	422431
0 - 100A	422303	422432
0 - 150A	422304	422433
0 - 250A	422578	422591
0 - 500A	422353	422434

Regulatory

Certifications	Directives/Standard
	RED 2014/53/EU Radio Equipment Regulations 2017
	FCC Part 15C
Safety	IEC 61010-1:2010

Installation

Neuron sensors are ready for use out of the box and will start logging data after registering the sensor in the app. Even though Neuron sensors deliver great range and long battery life, following some simple guidelines for mounting of the sensor and gateway can greatly improve signal coverage and lifetime of the sensor.

To ensure optimal antenna performance and signal strength, the sensor should be placed elevated with some distance to fixed objects. Keep in mind that RF-signals are greatly affected by close metallic surfaces.

For sensors with an external antenna, the antenna should be clear off the metallic surface.

For sensors operating in environments with greatly varying temperatures, care should be taken to avoid putting the sensor in unnecessary stress. Very high or low temperatures will affect the battery life and the signal strength of the sensor. While some sensors must be close to the source of heat or cold, other sensors have external probes which allow the sensor to be placed at a distance.

Fastening

The small, compact blue Neuron sensors are fitted with fastening holes for use with cable ties. The sensors are also delivered with double-sided tape that may be used for fastening of the sensors.

All the black Neuron sensors, like the Neuron IR380 and Neuron Vibration, are fitted with a strong magnet at the back for easy fastening. If there is no magnetic surface, then double-sided tape is a good solution.

You can find all you need to get started with Neuron Sensors at our support site: support.el-watch.com



Place elevated with distance to fixed objects



Keep antenna clear off the metallic surface



Sensors with IP21 Enclosure



Sensors with IP67 Enclosure

Dimensions

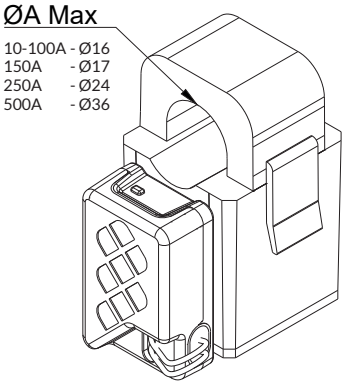

10-100A	- 49 mm
150A	- 58mm
250A	- 52 mm
500A	- 58 mm

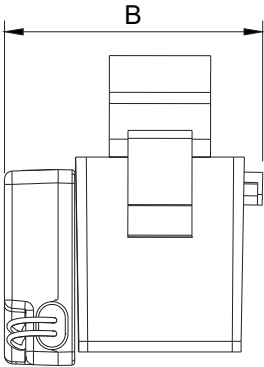

10-150A	- 34 mm
250A	- 49 mm
500A	- 61mm

10-100A	- 58 mm
150A	- 64mm
250A	- 77 mm
500A	- 94 mm

