

# KULVENTILER

## Kulventil K30 med pneumatiskt manöverdon

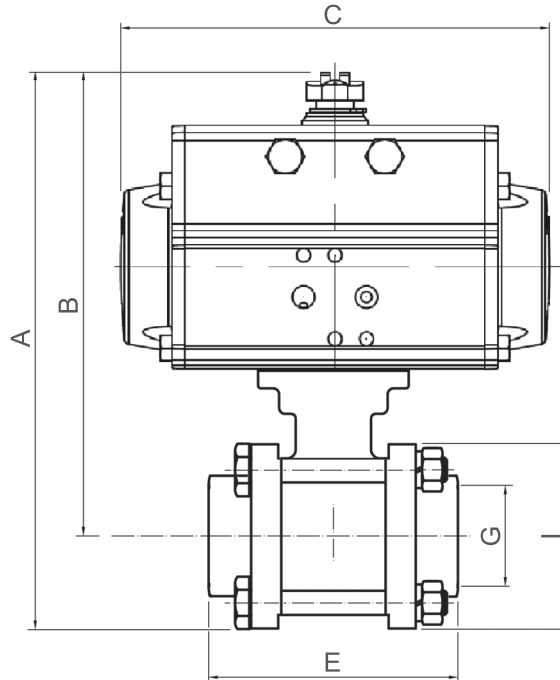
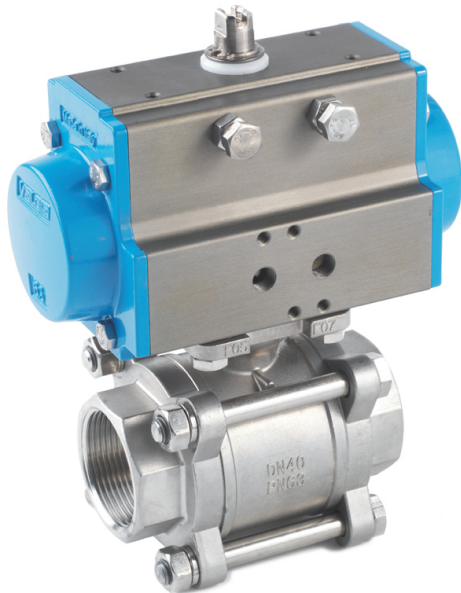

### Kulventil med dubbelverkande pneumatiskt manöverdon

Benämning	G"	A	B	C	E	I	Kg
K30-1/4"-DA32	1/4"	123	103	110	64	39	1,0
K30-3/8"-DA32	3/8"	125	103	110	64	44	1,0
K30-1/2"-DA32	1/2"	130	107	110	72	45	1,1
K30-3/4"-DA52	3/4"	177	150	141	80	54	1,9
K30-1"-DA52	1"	188	157	141	85	61	2,3
K30-1 1/4"-DA63	1 1/4"	210	173	164	105	74	3,6
K30-1 1/2"-DA63	1 1/2"	224	183	164	113	82	4,4
K30-2"-DA75	2"	265	216	210	132	97	7,1
K30-2 1/2"-DA85	2 1/2"	316	254	241	170	123	11,3
K30-3"-DA100	3"	346	276	275	186	139	15,6
K30-4"-DA115	4"	412	308	333	226	207	28,0

### Kulventil med enkelverkande pneumatiskt manöverdon

Benämning	G"	A	B	C	E	I	Kg
K30-1/4"-SR52	1/4"	160	140	141	64	39	1,8
K30-3/8"-SR52	3/8"	162	140	141	64	44	1,8
K30-1/2"-SR52	1/2"	167	144	141	64	45	1,9
K30-3/4"-SR52	3/4"	177	150	141	80	54	2,1
K30-1"-SR63	1"	199	168	164	87	61	3,2
K30-1 1/4"-SR75	1 1/4"	228	191	210	105	74	5,3
K30-1 1/2"-SR85	1 1/2"	256	215	241	116	82	7,5
K30-2"-SR100	2"	292	243	275	136	97	11,3
K30-2 1/2"-SR115	2 1/2"	363	301	333	170	123	18,9
K30-3"-SR125	3"	392	322	372	191	139	24,2
K30-4"-SR125	4"	424	320	372	243	207	33,2