

# Blancett®

## Flow Meters



### **Model 1100** Turbine Flow Meter

- Accurate and repeatable flow measurement from 0.6 - 3 gpm (20 - 100 BPD) to 500 - 5,000 gpm (17,000 - 171,000 BPD)
- Capable of electronic integration, to provide displayed flow rate, totalization, current or voltage outputs
- Capable of measuring flow on piping systems from 1/2" to 10"
- Superior materials of construction for high performance in aggressive environments
- Only one moving part for reduced maintenance costs



0240-150 09 • [www.kompauto.se](http://www.kompauto.se)

## Introduction

The Model 1100 Turbine Flow Meter is designed to withstand the demands of the most rigorous flow measurement applications. Originally developed for the secondary oil recovery market, the Model 1100 is an ideal meter for liquid flow measurement on or off the oilfield.

The meter features a rugged 316 stainless steel housing and rotor support assemblies, CD4MCU stainless steel rotor, and abrasive-resistant tungsten carbide rotor shaft and journal bearings. The Model 1100 maintains measurement accuracy and mechanical integrity in the corrosive and abrasive fluids commonly found in oil field water flood projects and many industrial applications.

Designed to operate with the Model B2800 Flow Monitor, the Model 1100 turbine meter meets a wide range of measurement requirements. This makes it ideal for applications such as pipelines, production/injection fields, in-situ mining operations, offshore facilities, and other industrial applications.



## Features

- Offers accurate and repeatable flow measurement in ranges from 0.6 to 5,000 GPM (20 to 171,000 BPD)
- Cost-effective solution for turbine flow meter applications
- Rugged 316 stainless steel construction offers long service life in severe operating environments
- Available in NPT, BSP, Victaulic®, Flange, or Hose Barbed end connections
- NIST traceable calibration
- Installation in pipe sizes from 1/2" to 10"
- Integrate electronically with B2800 Flow Monitor, K-Factor Scaler, or the F to I/F to V Intelligent Converter
- Field replaceable repair kits allow for turbine replacement without loss of accuracy

## Operating Principle

Fluid entering the meter passes through the inlet flow straightener which reduces its turbulent flow pattern and improves the fluid's velocity profile. Fluid then passes through the turbine, causing it to rotate at a speed proportional to fluid velocity. As each turbine blade passes through the magnetic field at the base of the transducer, an AC voltage pulse is generated in the pickup coil. These pulses produce an output frequency proportional to the volumetric flow through the meter.

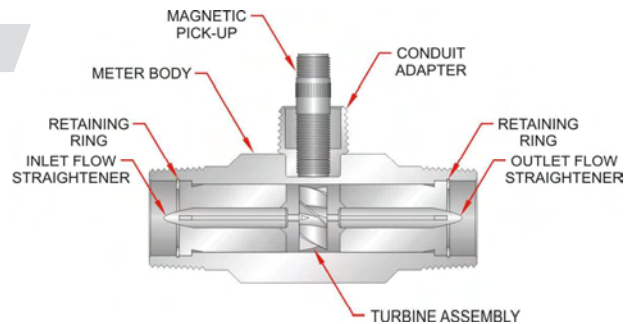

## Specifications

### Materials of Construction:

- Body; 316 Stainless Steel
- Rotor; CD4MCU Stainless Steel
- Rotor Support; 316 Stainless Steel
- Rotor Shaft; Tungsten Carbide

**Turndown Ratio:** 10:1

**Flow Accuracy:** ±1% of reading

**Repeatability:** ± 0.1%

**Calibration:** Water (NIST traceable calibration)

**Pressure Rating:** 5,000 psi (maximum)

**Turbine Temperature:** -150 °F to +350 °F  
(-101 °C to 177 °C)

**End Connections:** NPT, BSP, Victaulic®,  
Flange, Hose Barbed

Pressure Drop vs. Flow Rate

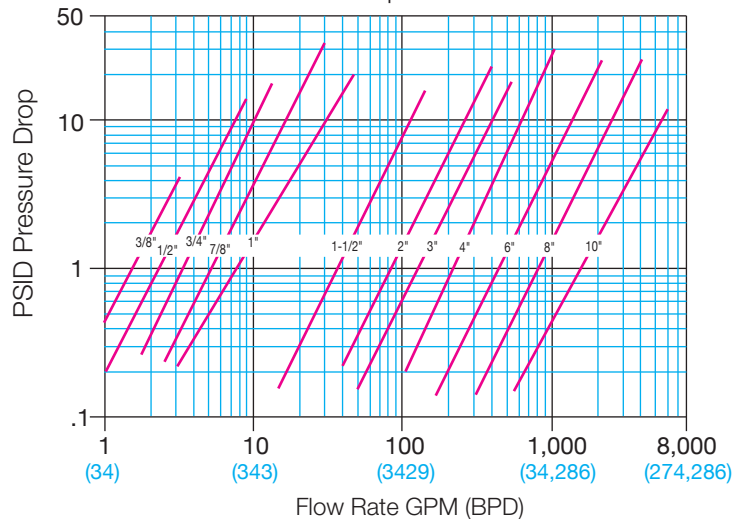

## Model 1100 Turbine Meters & Repair Kits

Part Number*	Bore Size	End Connections	Max. PSI	Flow Ranges			Recommended Strainer Mesh	Approx. K-Factor Pulses/Gal	Meter Weight	End to End Length	Repair Kit Part Number
				GPM	BPD	M <sup>3</sup> /D					
B110-375-1/2	3/8"	1/2" Male NPT	5,000	0.6 - 3	20 - 100	3.3 - 16	60	18,000	1	3"	B251-102
B110-500-1/2	1/2"	1/2" Male NPT	5,000	0.75 - 7.5	25 - 250	4.1 - 41	60	13,000	1	3"	B251-105
B110-750-1/2	3/4"	1/2" Male NPT	5,000	2 - 15	68 - 515	10.9 - 81.75	60	3,300	1	3"	B251-108
B110-375	3/8"	1" Male NPT	5,000	0.6 - 3	20 - 100	3.3 - 16	60	18,000	2	4"	B251-102
B110-500	1/2"	1" Male NPT	5,000	0.75 - 7.5	25 - 250	4.1 - 41	60	13,000	2	4"	B251-105
B110-750	3/4"	1" Male NPT	5,000	2 - 15	68 - 515	10.9 - 81.75	60	3,300	2	4"	B251-108
B110-875	7/8"	1" Male NPT	5,000	3 - 30	100 - 1,000	16 - 160	60	3,100	2	4"	B251-109
B111-110	1"	1" Male NPT	5,000	5 - 50	170 - 1,700	27.25 - 272.5	40	870	2	4"	B251-112
B111-115	1-1/2"	1-1/2" Male NPT	5,000	15 - 180	515 - 6,000	82 - 981	20	330	5	6"	B251-116
B111-121	1-1/2"	2" Male NPT	5,000	15 - 180	515 - 6,000	82 - 981	20	330	6	6"	B251-116
B111-120	2"	2" Female NPT	5,000	40 - 400	1,300 - 13,000	218 - 2,180	20	52	14	10"	B251-120
B111-130	3"	3" Grooved End	800	60 - 600	2,100 - 21,000	327 - 3,270	10	57	15	12-1/2"	B251-131
B111-140	4"	4" Grooved End	800	100 - 1,200	3,400 - 41,000	545 - 6,540	10	29	20	12"	B251-141
B111-160	6"	6" Grooved End	800	200 - 2,500	6,800 - 86,000	1,090 - 13,626	4	7	46	12"	B251-161
B111-180	8"	8" Grooved End	800	250 - 3,500	12,000 - 120,000	1,363 - 19,076	4	3	56	12"	B251-181
B111-200	10"	10" Grooved End	800	500 - 5,000	17,000 - 171,000	2,725 - 27,252	4	1.6	80	12"	B251-200

\* Part number includes turbine meter and standard magnetic pickup. For other pickup options, see table below.

## Installation

The Model 1100 Turbine Meter is simple to install and service. It operates in any orientation (horizontal to vertical) as long as the "flow direction" arrow is aligned in the same direction as the actual line flow. For optimum performance, the flow meter should be installed with a minimum of 10 diameters upstream straight pipe length and 5 diameters downstream straight pipe length.

## Repair Kits

Factory calibrated replacement kits are available for field or factory service. This is of particular importance when fluids contain abrasive contaminants and meters require frequent service.

A repair kit contains two retaining rings, two rotor supports, one rotor assembly, and a K-Factor tag. The rotor support assembly is retained in proper position within the meter body by retainer rings. These rings allow for quick and easy disassembly and replacement of the meter's internal components. The Model 1100 repair kits are designed and manufactured for use with Blancett turbines and other flow meters of similar design; contact the factory or refer to Form #4300 for further details.

## K-Factor

The K-Factor represents the number of output pulses transmitted per gallon of fluid passing through the turbine meter. Each turbine has a unique K-Factor. However, turbine meters are not functionally consistent throughout the full flow range of the meter.

There are several forms of "friction" inherent in turbine meters that retard the rotational movement of the turbine rotor. These frictional forces include: magnetic drag, created by electromagnetic force of pickup transducers; mechanical drag, due to bearing friction; and viscous drag, produced by flowing fluid. See charts at right.

As flow increases, the frictional forces are minimized and the free-wheeling motion of the turbine rotor becomes more linear (proportional to flow). The K-Factor becomes relatively constant and linear throughout the balance of the linear flow range. This is approximately a 10:1 turndown ratio from the maximum flow rate down to the minimum flow rate.

## Model 1100 Pickup Options

Part Number	Magnetic Pickup	Temperature Range
B111109	Standard	-150 °F to +330 °F (-101 °C to +165 °C)
B220111	High Temperature	-150 °F to +450 °F (-101 °C to +232 °C)
B220210	with Preamplifier	-20 °F to +160 °F (-29 °C to +71 °C)
B220243	Intrinsically Safe, FM rated	-150 °F to +330 °F (-101 °C to +165 °C)

Typical K-Factor Curve (Pulses per Gallon)

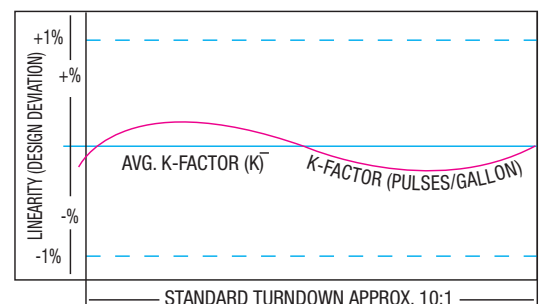
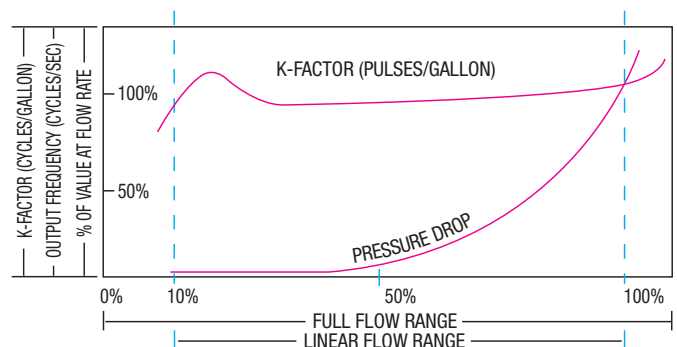

## B2800 Flow Monitor

- Microprocessor-based flow monitor and totalizer
- Use with Blancett turbine flow meters as well as other flow meters with a frequency output
- Battery (1.5 VDC) and loop-powered (4-20 mA) versions
- Meter, remote, panel and swivel mounting options
- Hand-held and explosion-proof models also available
- CSA and CE approved
- Class 1, Division 1 (Intrinsically Safe) certification



## K-Factor Scaler Frequency Divider

- Scales turbine meter output to desired engineering units
- Amplifies turbine meter pulse output
- Converts frequency outputs into recognizable units for PLCs and other devices
- Switch-selectable or programmable versions available
- CSA approved



## F to I / F to V Intelligent Converter

- Microprocessor-based
- Linearized output capability
- Choice of 4-20 mA or 0-5 VDC output
- Enables integration with data acquisition devices
- Frequency measurement accuracy  $\pm 1\%$
- CSA approved

